

Baureihe 0270 (SWMK)

Motortyp 403 033

Technische Daten

Nennspannung	U_N	[Volt]	24
Leerlaufdrehzahl	n_0	[min ⁻¹]	13
Nenn Drehmoment	M_N	[Nm]	5,0
Einschaltdauer		%	
EIN		[min]	
Anlaufmoment	M_A	[Nm]	15,0
Getriebeübersetzung	i		78/1
Anschlusswiderstand	2 Lamellen	R	[mΩ] 5000,0
	4 Lamellen	R	[mΩ] 4400,0
Anschlussinduktivität	2 Lamellen	L	[mH] 9,80
	4 Lamellen	L	[mH] 8,70
Läuferträgheitsmoment	J_R	[kgm ²] × 10 ⁻⁶	64,0
Zahnradwerkstoff			Bronze
Hall IC			
Impuls/Umdrehung Abtriebswelle			
Ausgangskanäle			
Bemerkungen			ohne Kappe
Schutzart			IP 30
Gewicht		[kg]	1,20

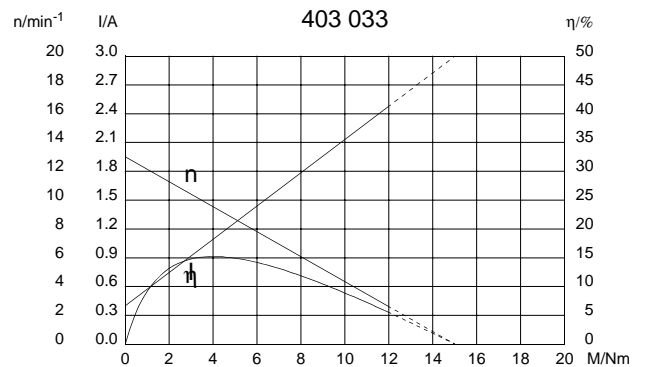
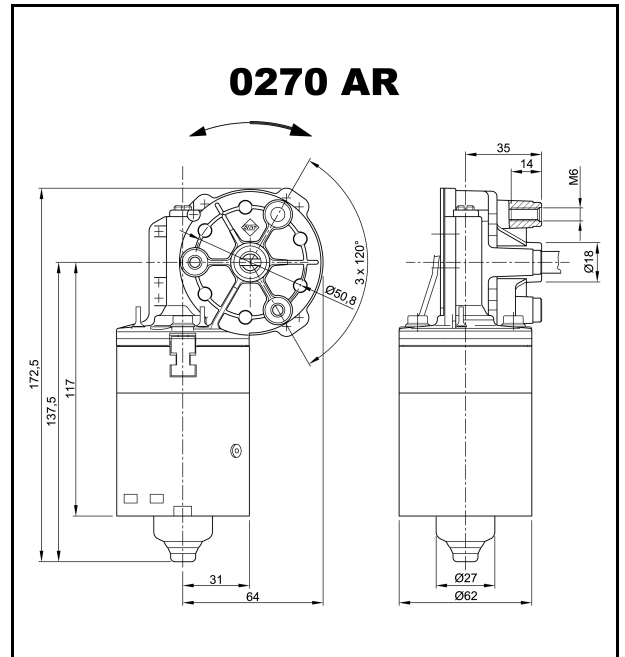

W 114

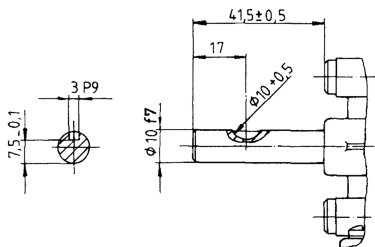

W 197

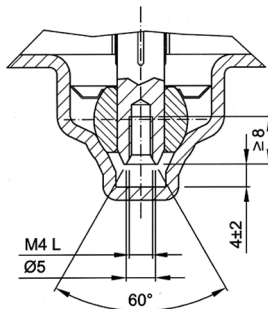

S 28

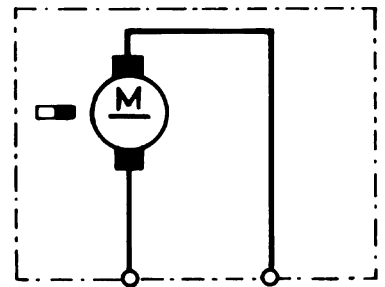

K 53

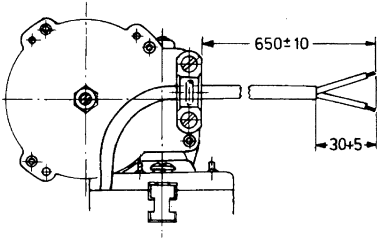

Notizfeld: