

Series SWMP

Motor type 403 194

Design Data	
Commutation	Brushed
Direction of rotation	Bi-directional
Bearing type	

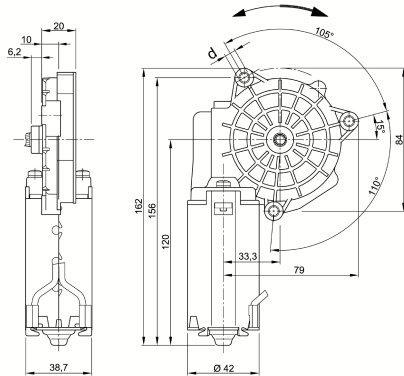

Performance data		
Rated voltage [V]	U_N	24
Nominal torque [Nm]	M_N	2.00
No-load speed [min^{-1}]	n_0	50.0
Nominal power [W]	P_N	8.73
Nominal current [A]	I_N	1.5
Nominal force [kN]	F_N	0.00
Duty cycle		s1

Sensor data	
Pulses	0
Output channels	0

Other data	
Gear ratio	85/1
Gear wheel material	Resinbonded fabric
Suppression components	
Enclosure class	IP30
Weight [kg]	0.710

Remarks: d = M6

Motor picture

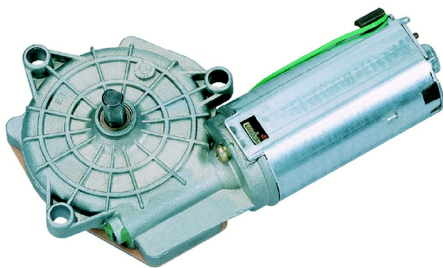

Characteristic curves

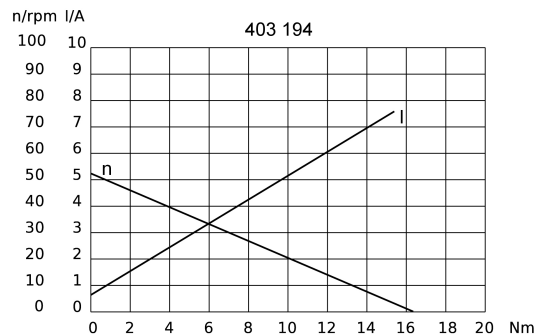

Output shaft drawing (W), Wiring diagrams (S) and Connector layout (K)

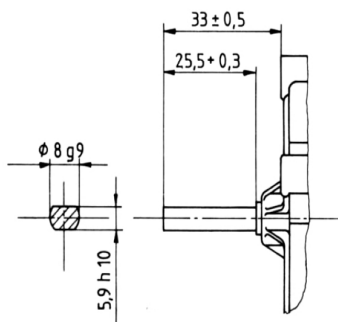

S 28

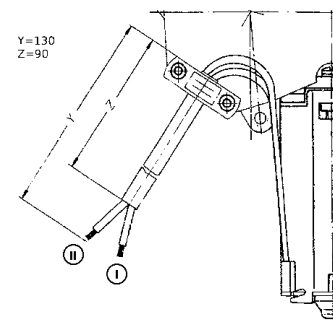
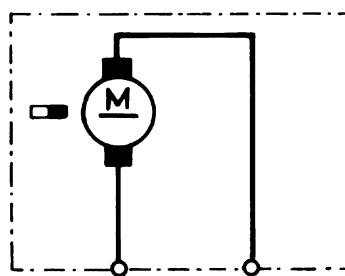

I: green
II: black