

Series SW2L

Motor type 404 148

Design Data	
Commutation	Brushed
Direction of rotation	Bi-directional
Bearing type	A:Ball - B:Sleeve

Performance data		
Rated voltage [V]	U_N	24
Nominal torque [Nm]	M_N	6.00
No-load speed [min^{-1}]	n_0	48.0
Nominal power [W]	P_N	27.9
Nominal current [A]	I_N	6.0
Nominal force [kN]	F_N	0.00
Duty cycle	s1	

Sensor data	
Pulses	0
Output channels	0

Other data	
Gear ratio	74/1
Gear wheel material	plastic
Suppression components	4,7 μ H, 1 μ F
Enclosure class	IP40
Weight [kg]	1.716

Remarks:

0278 AR

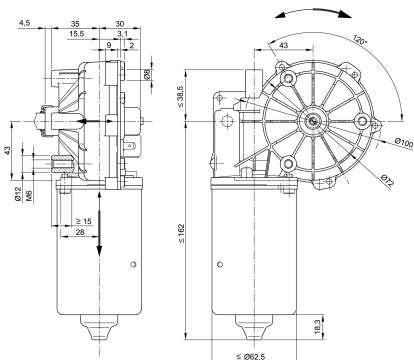

Motor picture

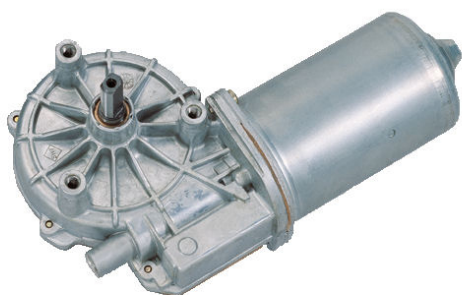

Characteristic curves

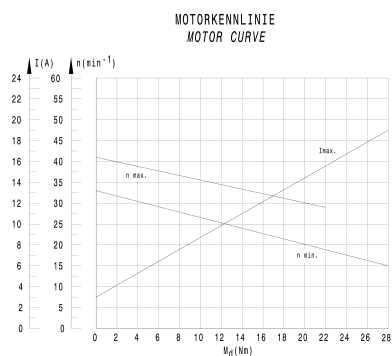

Output shaft drawing (W), Wiring diagrams (S) and Connector layout (K)

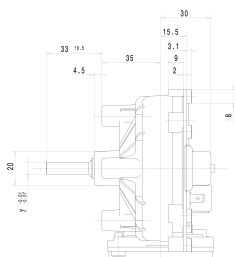

S 30

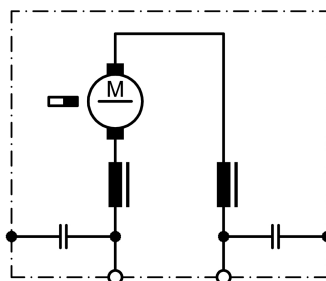

K 144

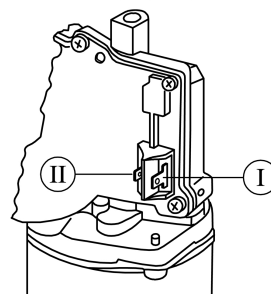

I - Blade terminal ends 6,3 x 0,8 DIN 46 244

II - Blade terminal ends 4,8 x 0,8 DIN 46 244