

Series GMPG

Motor type 404 157

Design Data	
Commutation	Brushed
Direction of rotation	Bi-directional
Bearing type	A:Sleeve - B:Sleeve

Performance data		
Rated voltage [V]	U_N	24
Nominal torque [Nm]	M_N	0.50
No-load speed [min^{-1}]	n_0	540.0
Nominal power [W]	P_N	24.7
Nominal current [A]	I_N	2.0
Nominal force [kN]	F_N	0.00
Duty cycle	s3	

Sensor data	
Pulses	0
Output channels	0

Other data	
Gear ratio	56/4
Gear wheel material	plastic
Suppression components	7,5 μ H, 1nF
Enclosure class	IP 30
Weight [kg]	0.710

Remarks: d = for thread-forming screw M 5 DIN 7500

Characteristic curves

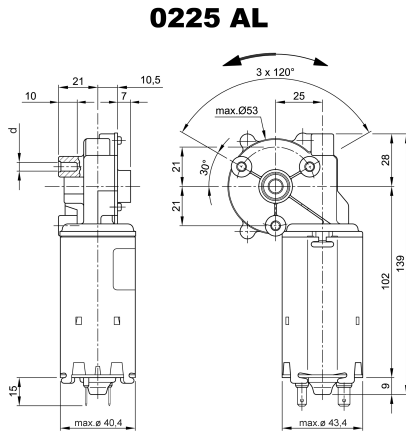

Motor picture

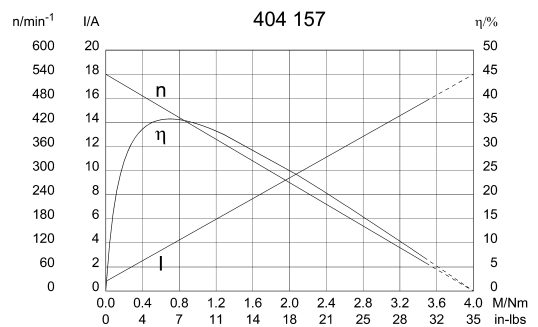

Output shaft drawing (W), Wiring diagrams (S) and Connector layout (K)

W 148

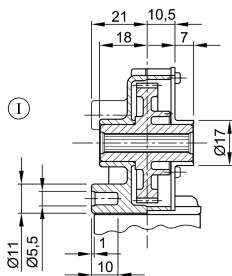

I Tapered splines 7 x 8 DIN 5481 continuous

S 74

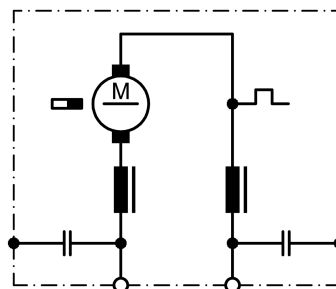

K 117

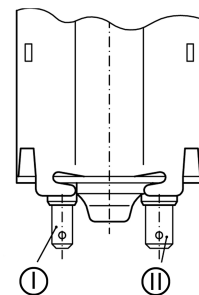

I Blade terminal ends 4,8 x 0,8 DIN 46 244
II Blade terminal ends 6,3 x 0,8 DIN 46 244