

Series 0270 (SWMK)

Motor type 404 354

Technical Data			
Rated voltage	U_N	[Volt]	24
No-load speed	n_0	[min ⁻¹]	64
Nominal torque	M_N	[Nm]	4,00
ON time		%	
ON		[min]	
Starting torque	M_A	[Nm]	26,00
Gear ratio	i		69/1
Armature resistance, 2 bars	R	[mΩ]	550,00
	R	[mΩ]	650,00
Armature inductance, 2 bars	L	[mH]	1,16
	L	[mH]	1,06
Armature load inertia	J_R	[kgm ²] × 10 ⁻⁶	57,00
Gear wheel material			plastic
Hall IC			
Pulses/rev. drive shaft			
Output channels			
Remarks			
Enclosure class			IP 30
Weight		[kg]	1,030

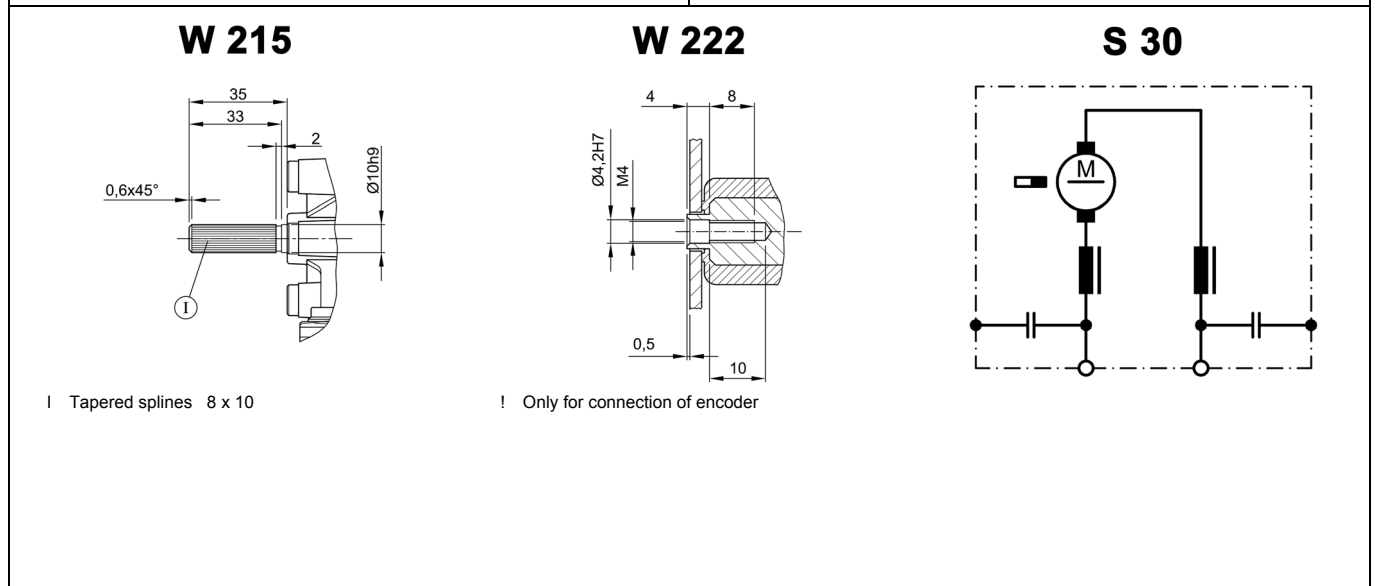
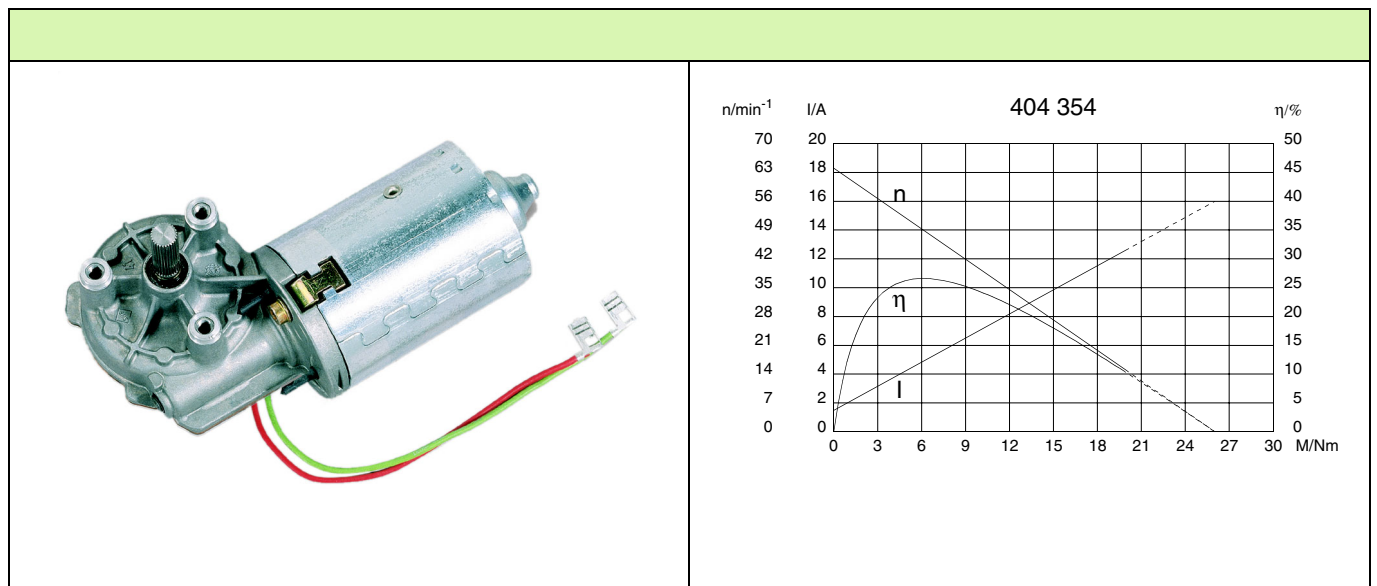
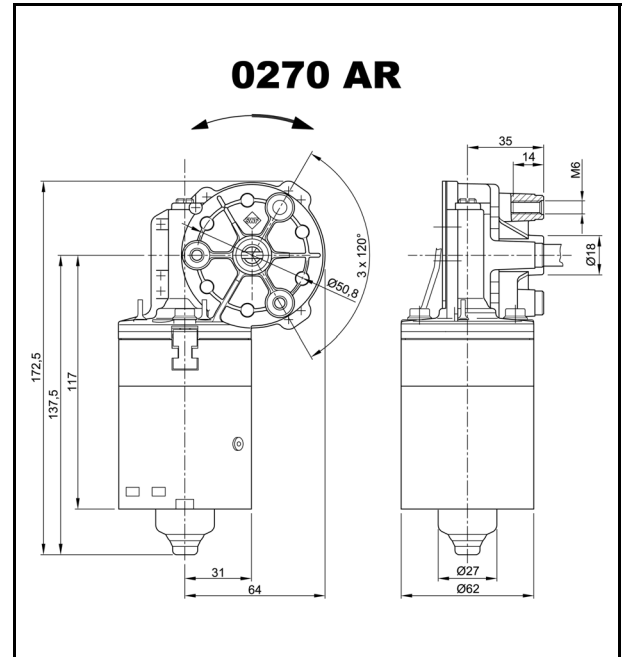

Series 0270 (SWMK)

Motor type 404 354

K 208

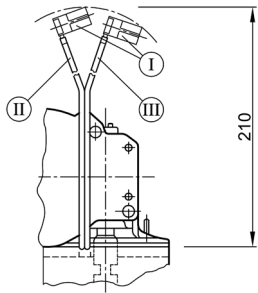

- I Blade receptacles 6,3 x 0,8
Grothe+Hartmann-Nr. 25.505.123.211
- II Terminal 2, green
- III Terminal 1, red

Notes: