

Series GMP

Motor type 404 476

Design Data	
Commutation	Brushed
Direction of rotation	Bi-directional
Bearing type	A:Sleeve - B:Sleeve

Performance data		
Rated voltage [V]	U_N	12
Nominal torque [Nm]	M_N	0.05
No-load speed [min^{-1}]	n_0	3,250.0
Nominal power [W]	P_N	14.0
Nominal current [A]	I_N	3.5
Nominal force [kN]	F_N	0.00
Duty cycle		s3

Sensor data	
Pulses	2
Output channels	1

Other data	
Gear ratio	
Gear wheel material	
Suppression components	7,5 μ H
Enclosure class	IP 40
Weight [kg]	0.520

Remarks:

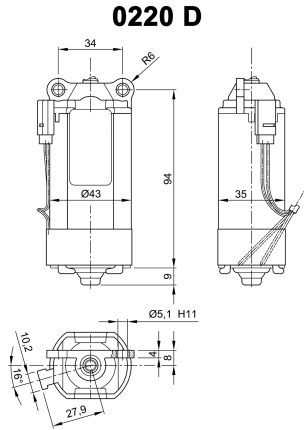

Motor picture

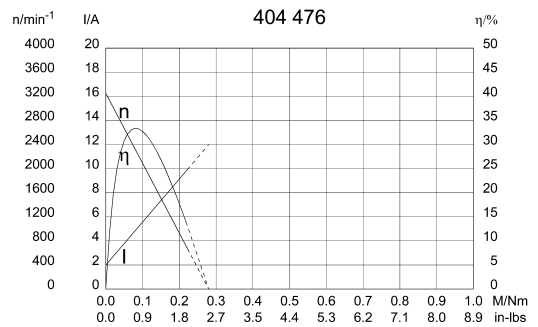
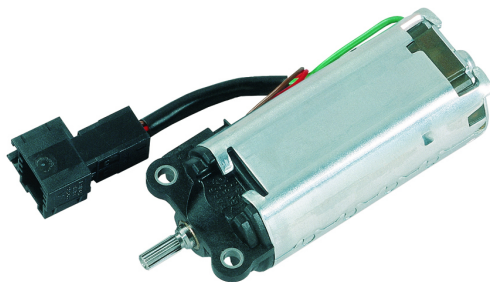

Output shaft drawing (W), Wiring diagrams (S) and Connector layout (K)

W 256

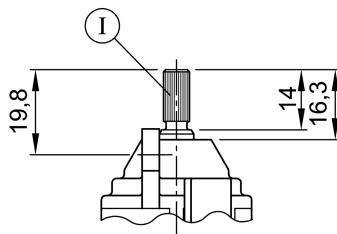

I Tapered splines 5 x 6 DIN 5481

S 82

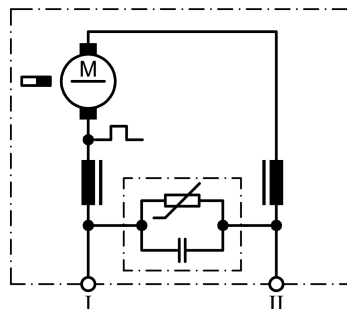

I Terminal 1, green
II Terminal 2, black

S 92

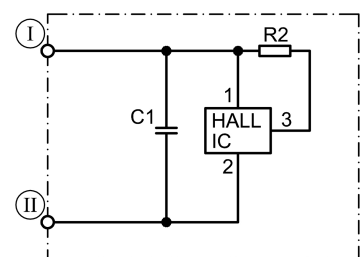

I Terminal 3, +, red
II Terminal 4, -, brown

