

Series 0225 (GMPG)

Motor type 404 748

Technical Data

Rated voltage	U_N [Volt]	12
No-load speed	n_0 [min^{-1}]	21
Nominal torque	M_N [Nm]	3,00
ON time	%	10
ON	[min]	
Starting torque	M_A [Nm]	19,60
Gear ratio	i	210/1
Armature resistance, 2 bars	R [$\text{m}\Omega$]	1110,00
4 bars	R [$\text{m}\Omega$]	630,00
Armature inductance, 2 bars	L [mH]	0,90
4 bars	L [mH]	0,54
Armature load inertia	J_R [kgm^2] $\times 10^{-6}$	9,50
Gear wheel material	plastic	
Hall IC	X	
Pulses/rev. drive shaft		210,00
Output channels		1
Remarks	Plastic gearbox	
Enclosure class		IP 40
Weight	[kg]	0,440

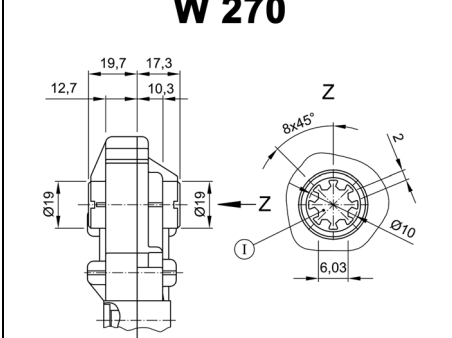
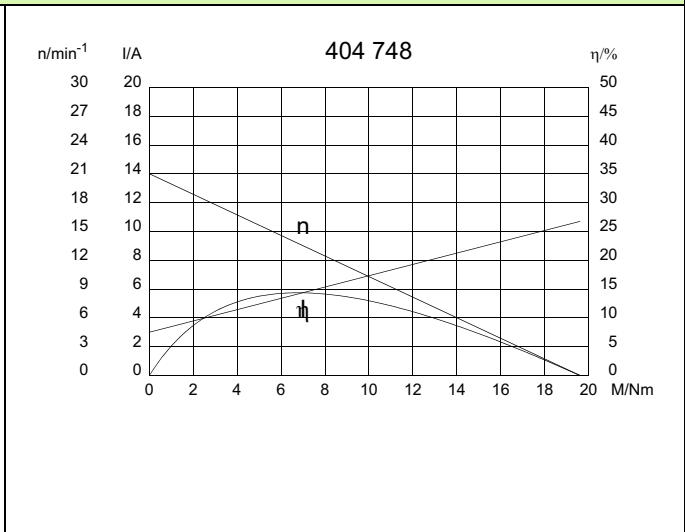
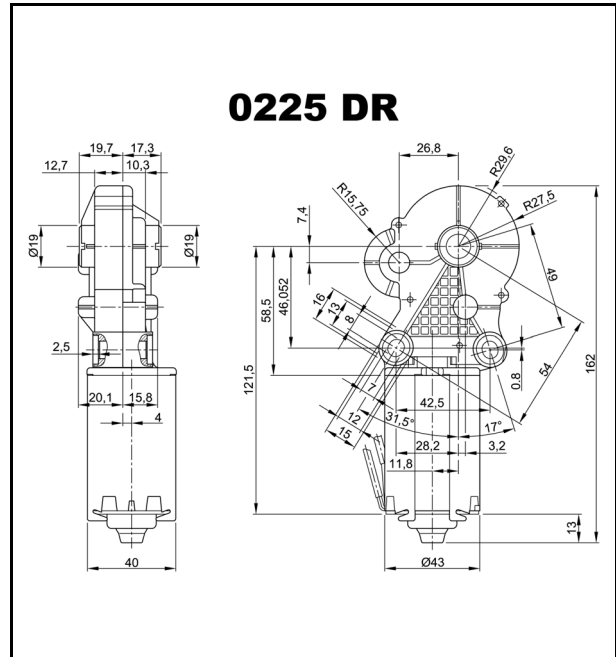

I Profile continous

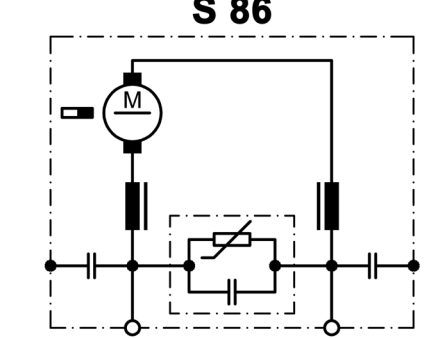

I Terminal 1
II Terminal 5

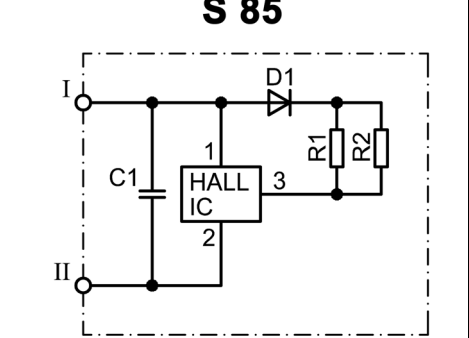

I Terminal 4, Hall-IC +
II Terminal 2, Hall-IC -

Series 0225 (GMPG)

Motor type 404 748

K 220



- I Terminal housing 5-pole
TYCO C-208-15621 (Z)
- II Mating connector TYCO 1379217
+ TYCO 1379218

Notes: