

Series 0266 (DCK31)

Motor type 404 853

Technical Data			
Rated voltage	U_N	[Volt]	24
No-load speed	n_0	[min ⁻¹]	65
Nominal torque	M_N	[Nm]	4,00
ON time		%	
ON		[min]	
Starting torque	M_A	[Nm]	50,00
Gear ratio	i		69/1
Armature resistance, 2 bars	R	[m Ω]	
4 bars	R	[m Ω]	
Armature inductance, 2 bars	L	[mH]	
4 bars	L	[mH]	
Armature load inertia	J_R	[kgm ²] × 10 ⁻⁶	
Gear wheel material		plastic	
Hall IC			
Pulses/rev. drive shaft			
Output channels			
Remarks		d = for self-tapping screw	M 6
Enclosure class			IP 30
Weight		[kg]	1,210

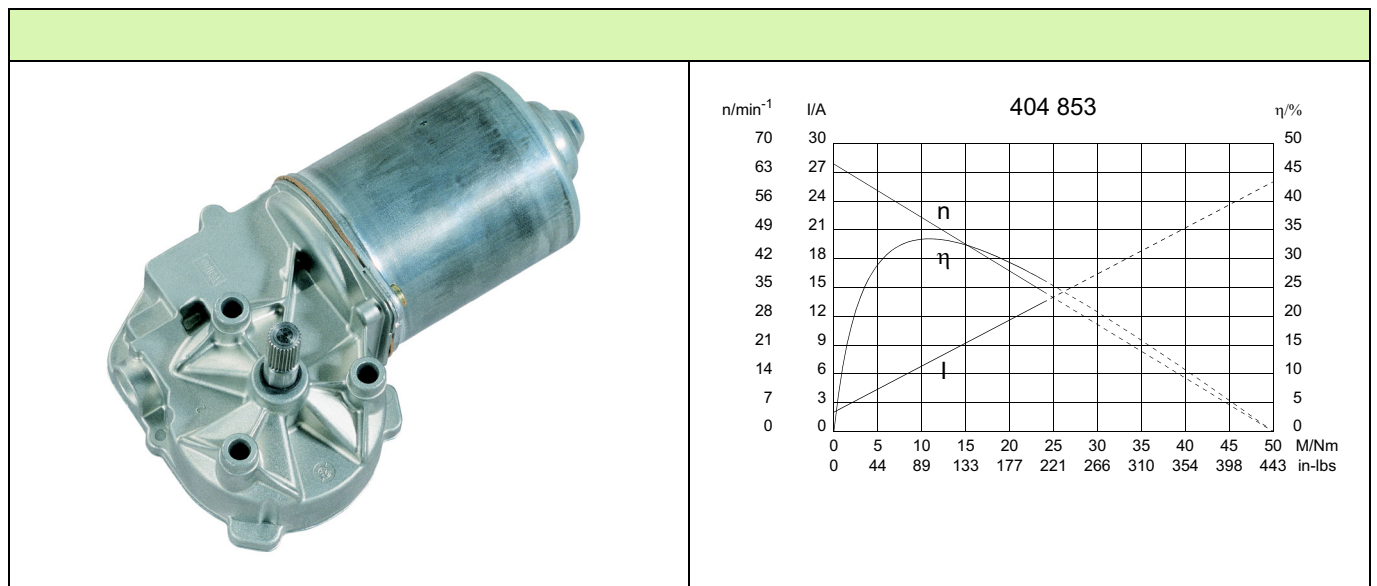
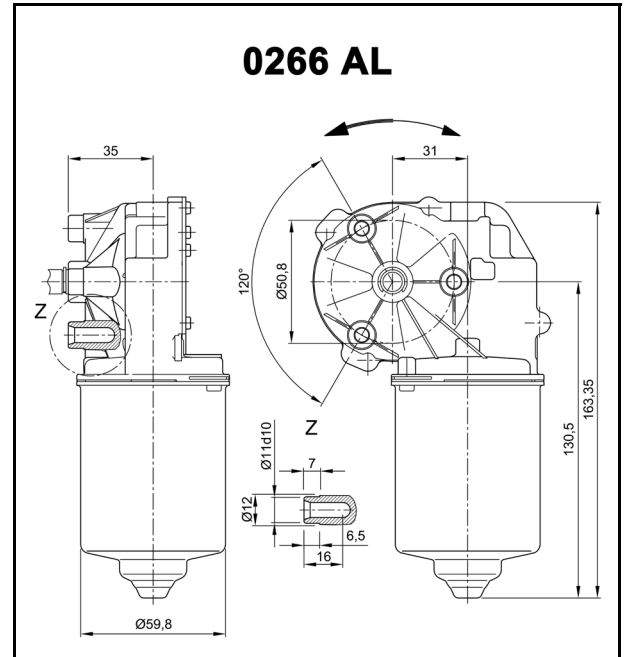

W 216

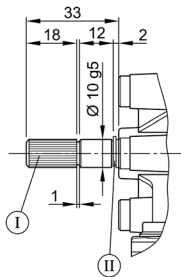

- I Tapered splines 8 x 10 (similar DIN 5481)
- II Circlip DIN 471

S 27

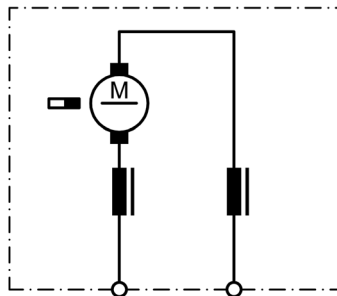

K 249

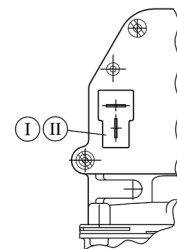

- I Blade terminal 6,3mm
- II Mating connector: AMP PE 926474-1 with terminal AMP PE 5-0160558-2