

# Series DCK31

## Motor type 404 854

Design Data	
Commutation	brushed
Direction of rotation	bidirectional
Bearing Type	A:ball - B:sleeve

Performance data		
Nominal Voltage [V]	$U_N$	24
Nominal Torque [Nm]	$M_N$	4,00
Nominal Speed [ $\text{min}^{-1}$ ]	$n_N$	59,8
Nominal Power [W]	$P_N$	25,0
Nominal current [A]	$I_N$	4,0
Nominal force [kN]	$F_N$	0,00
Duty cycle	s1	

Sensor data	
Pulses	69
Output channels	1

Other data	
Gear ratio	69/1
Gear wheel material	plastic
Suppression components	6 $\mu\text{H}$
Enclosure class	IP 30
Weight [kg]	1,250

Remarks:  
d=for selftapping screw M6 DIN ISO 965-2

### Characteristic Curves

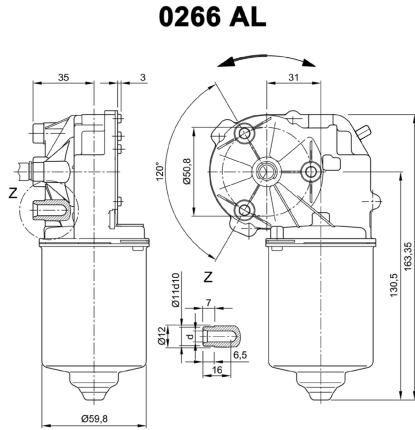

### Motor picture

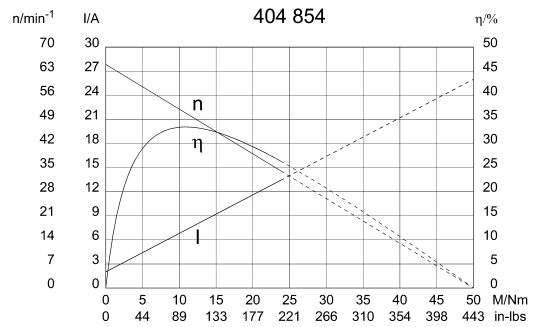

### Output shaft drawing (W), Wiring diagrams (S) and Connector layout (K)

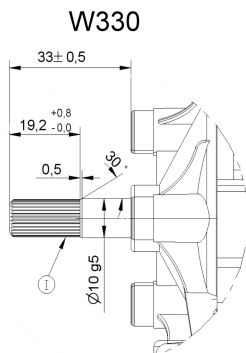

### S 27

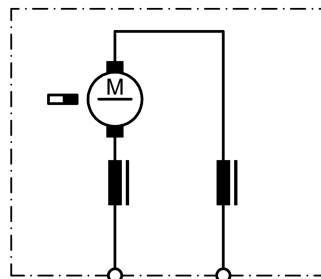

### S150

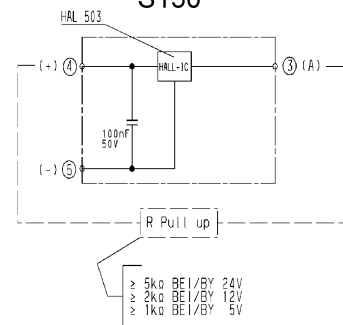

I serration (rolled)  
no of teeth 28, pitch circle dia 9 mm, tip circle dia 9,6 mm, root circle dia 8,26 mm space width angle 60°

