

# Series DCK31

## Motor type 404 866

Design Data	
Commutation	brushed
Direction of rotation	bidirectional
Bearing Type	A:ball - B:sleeve

Performance data		
Nominal Voltage [V]	$U_N$	24
Nominal Torque [Nm]	$M_N$	4,00
Nominal Speed [ $\text{min}^{-1}$ ]	$n_N$	58,182
Nominal Power [W]	$P_N$	24,4
Nominal current [A]	$I_N$	4,0
Nominal force [kN]	$F_N$	0,00
Duty cycle	s1	

Sensor data	
Pulses	0
Output channels	0

Other data	
Gear ratio	69/1
Gear wheel material	plastic
Suppression components	$6\mu\text{H}$ , $1\text{nF}$
Enclosure class	IP 30
Weight [kg]	1,216

Remarks:

d = for thread-forming screw M6 DIN ISO 965-2

### Characteristic Curves

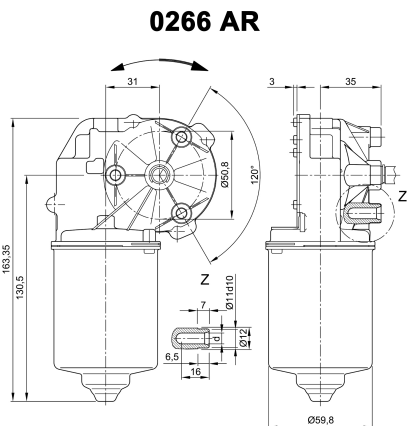

### Motor picture

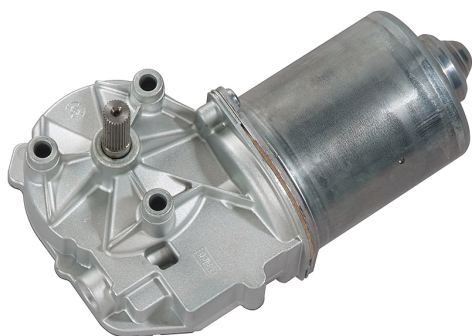

### Output shaft drawing (W), Wiring diagrams (S) and Connector layout (K)

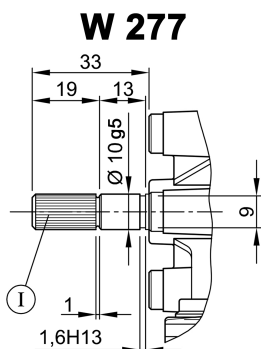

I serration (rolled)  
 no of teeth 28, pitch circle dia 9 mm, tip circle dia 9,6 mm, root circle dia 8,26 mm space width angle  $60^\circ$   
 goes with go/no go gauge Frenco 33906  
 www.frenco.de

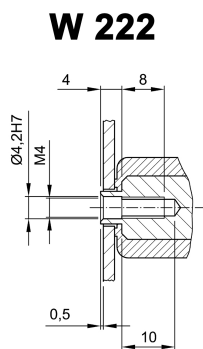

! Only for connection of encoder

