

Series DCK35

Motor type 404 885

Design Data	
Commutation	Brushed
Direction of rotation	Bi-directional
Bearing type	A:Ball - B:Sleeve

Performance data		
Rated voltage [V]	U_N	24
Nominal torque [Nm]	M_N	5.00
No-load speed [min^{-1}]	n_0	62.0
Nominal power [W]	P_N	29.8
Nominal current [A]	I_N	5.5
Nominal force [kN]	F_N	0.00
Duty cycle	s1	

Sensor data	
Pulses	63
Output channels	2

Other data	
Gear ratio	63/1
Gear wheel material	plastic
Suppression components	3,5 μ H
Enclosure class	IP 30
Weight [kg]	1.250

Remarks: d = for thread-forming screw M6 DIN ISO 965-2

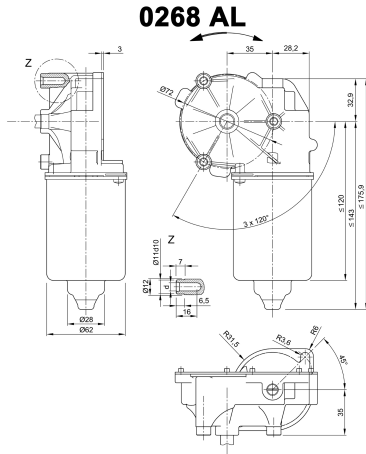

Motor picture



Characteristic curves

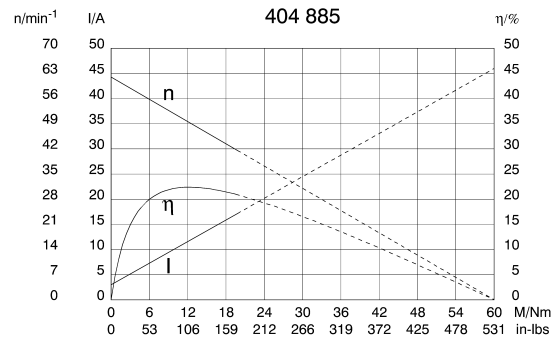

Output shaft drawing (W), Wiring diagrams (S) and Connector layout (K)

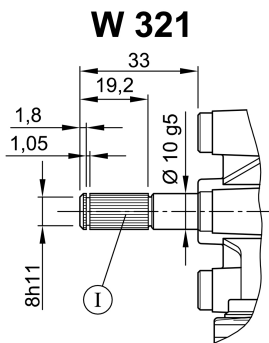

I serration (rolled): no of teeth 28, pitch circle dia 9 mm, tip circle dia 9.6 mm, root circle dia 8.26 mm space width angle 60°- go/no go gauge Frenco 33906 - www.frenco.de

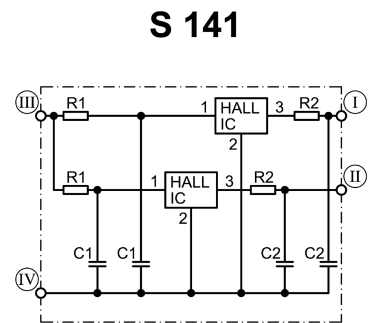
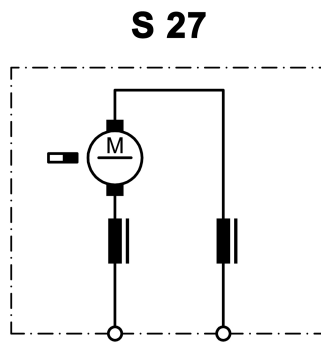

I Hall-IC A1, terminal 3
 II Hall-IC A2, terminal 4
 III Hall-IC +, terminal 5
 IV Hall-IC -, terminal 6

