

Series DCK31

Motor type 404 990

Design Data	
Commutation	brushed
Direction of rotation	bidirectional
Bearing Type	A:Ball - B:Sleeve

Performance data		
Nominal Voltage [V]	U_N	24
Nominal Torque [Nm]	M_N	3,00
Nominal Speed [min^{-1}]	n_N	167,143
Nominal Power [W]	P_N	52,5
Nominal current [A]	I_N	5,0
Nominal force [kN]	F_N	0,00
Duty cycle	s1	

Sensor data	
Pulses	207
Output channels	1

Other data	
Gear ratio	53/2
Gear wheel material	plastic
Suppression components	$6\mu\text{H}$, 1nF
Enclosure class	IP 30
Weight [kg]	1,210

Remarks:

d = for thread-forming screw M6 DIN ISO 965-2

Characteristic Curves

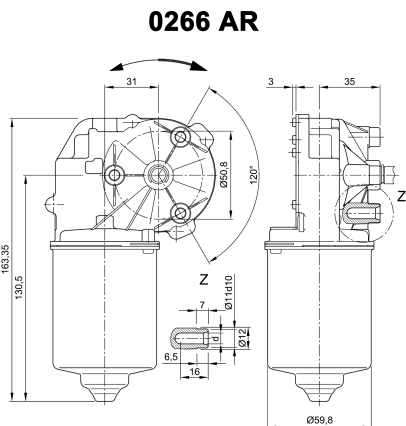

Motor picture

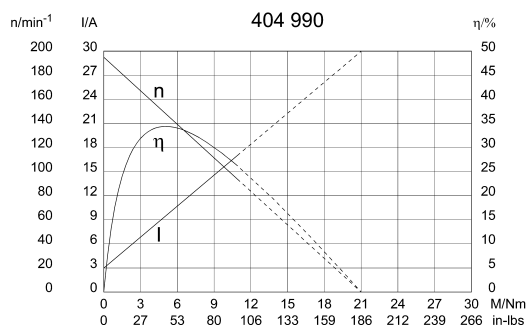
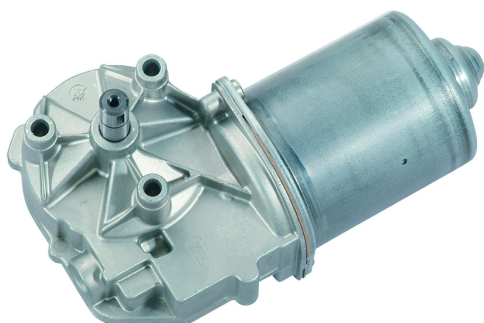

Output shaft drawing (W), Wiring diagrams (S) and Connector layout (K)

