

# Series GMPS

## Motor type 405 092

Design Data	
Commutation	Brushed
Direction of rotation	Bi-directional
Bearing type	A: Sleeve - B: Sleeve

Performance data		
Rated voltage [V]	$U_N$	12
Nominal torque [Nm]	$M_N$	1.50
No-load speed [ $\text{min}^{-1}$ ]	$n_0$	145.0
Nominal power [W]	$P_N$	16.6
Nominal current [A]	$I_N$	6.0
Nominal force [kN]	$F_N$	1.50
Duty cycle		s3

### 0321 BL

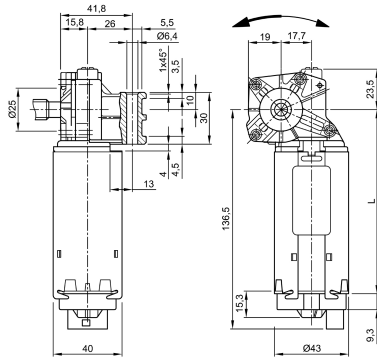

Sensor data	
Pulses	0
Output channels	0

Other data	
Gear ratio	29/1
Gear wheel material	
Suppression components	5,5 $\mu$ H, 47nF, (0,47 $\mu$ F)
Enclosure class	IP40
Weight [kg]	0.880

Remarks: 1 start worm

### Motor picture



### Characteristic curves

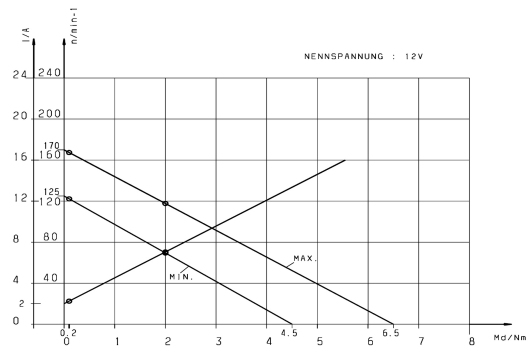

### Output shaft drawing (W), Wiring diagrams (S) and Connector layout (K)

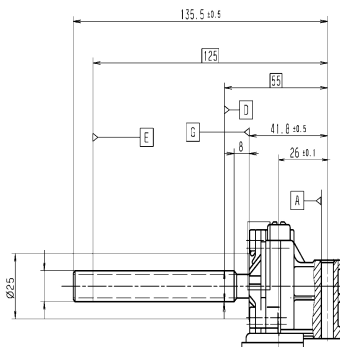

Output spindle: 7 / 16 Stub ACME RH

### S 93

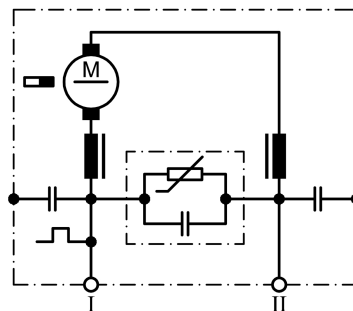

I Terminal 1  
II Terminal 5

### K 220

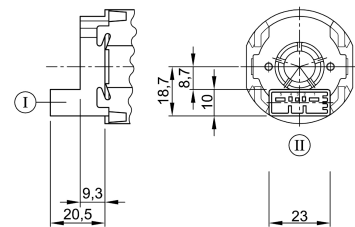

Connector TYCO C-208-15621 (Z) mating with:  
Connector housing 1379217-3 & cover  
1379218-2  
[www.tycoelectronics.com](http://www.tycoelectronics.com)