

Series DCK31

Motor type 405 251

Design Data	
Commutation	Brushed
Direction of rotation	Bi-directional
Bearing type	A: Ball - B: Sleeve

Performance data		
Rated voltage [V]	U_N	24
Nominal torque [Nm]	M_N	2.00
No-load speed [min^{-1}]	n_0	120.0
Nominal power [W]	P_N	22.0
Nominal current [A]	I_N	4.0
Nominal force [kN]	F_N	0.00
Duty cycle	s1	

Sensor data	
Pulses	79.5
Output channels	1

Other data	
Gear ratio	53/2
Gear wheel material	Plastic
Suppression components	6.0 μ H, 1nF
Enclosure class	IP30
Weight [kg]	1.210

Remarks: d = for thread-forming screw M6 DIN ISO 965-2

Characteristic curves

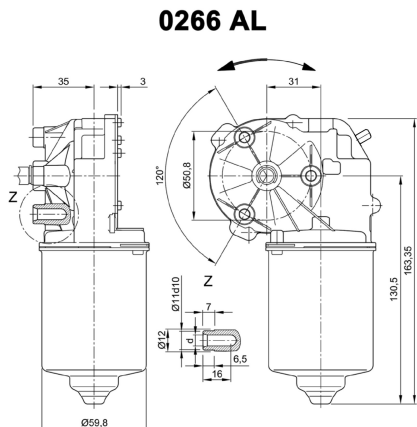

Motor picture

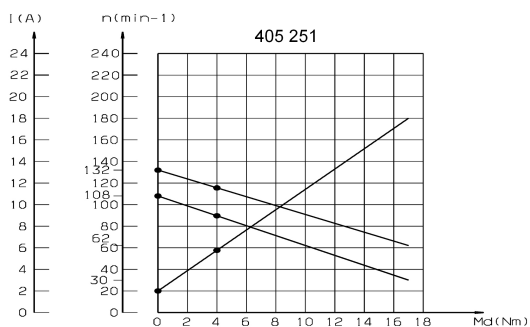
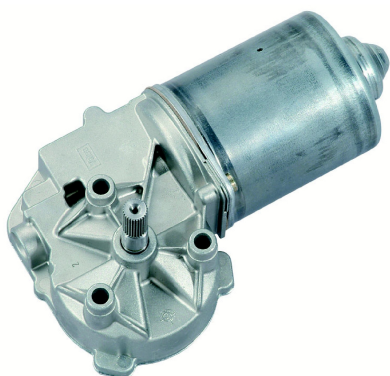

Output shaft drawing (W), Wiring diagrams (S) and Connector layout (K)

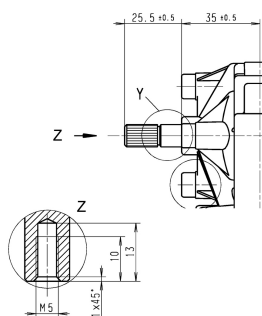

S 30

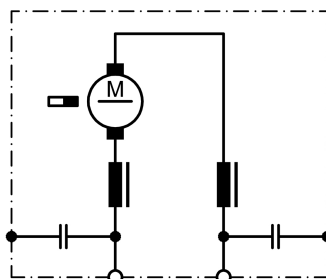

S 124

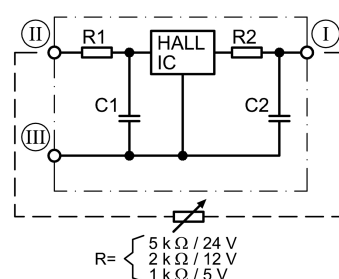

I serration (rolled): No teeth 28, pitch circle dia 9 mm, tip circle dia 9.6 mm, root circle dia 8.26 mm space width angle 60° - go/no go gauge Frenco 33906 - www.frenco.de

I Terminal 3, A
II Terminal 4, +
III Terminal 5, -

