

Baureihe 0270 (SWMK)

Motortyp 403 855

Technische Daten

Nennspannung	U_N	[Volt]	24
Leerlaufdrehzahl	n_0	[min ⁻¹]	35
Nennmoment	M_N	[Nm]	5,0
Einschaltdauer		%	
EIN		[min]	
Anlaufmoment	M_A	[Nm]	42,0
Getriebeübersetzung	i		69/1
Anschlusswiderstand	2 Lamellen	R	[mΩ] 1520,0
	4 Lamellen	R	[mΩ] 1350,0
Anschlussinduktivität	2 Lamellen	L	[mH] 3,40
	4 Lamellen	L	[mH] 3,00
Läuferträgheitsmoment	J_R	[kgm ²] × 10 ⁻⁶	74,0
Zahnradwerkstoff			Kunststoff
Hall IC			
Impuls/Umdrehung Abtriebswelle			
Ausgangskanäle			
Bemerkungen			ohne Kappe
Schutzart			IP 30
Gewicht		[kg]	1,20

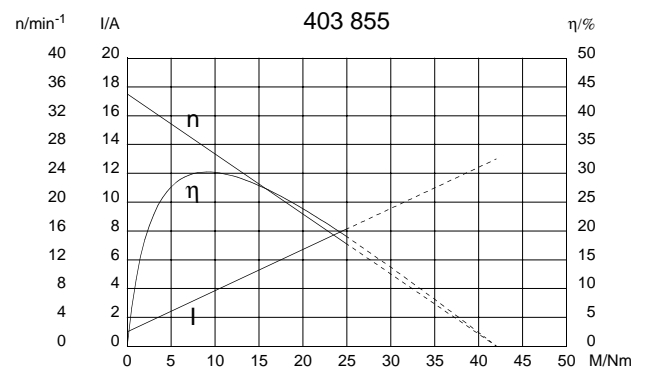
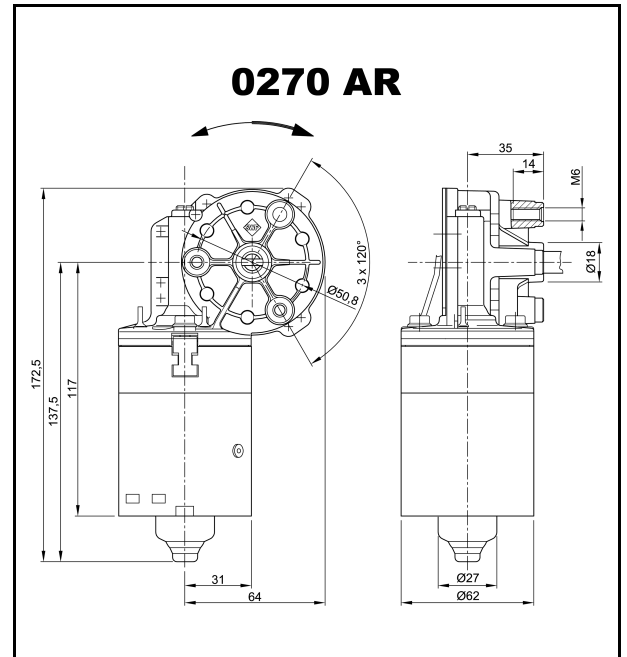

W 199

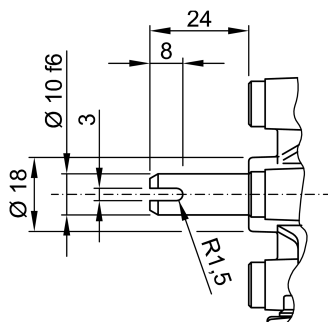

S 27

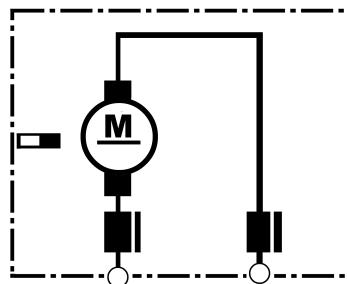

K 191

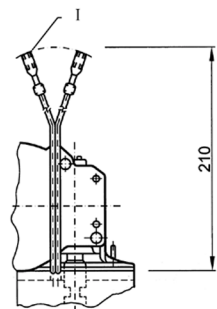

I Flachsteckhülsen 2,8 x 0,8 DIN 46 247