

Design Data	
Commutation	Brushed
Direction of rotation	Bi-directional
Bearing type	A:Sleeve - B:Sleeve

Performance data		
Rated voltage [V]	$U_N$	12
Nominal torque [Nm]	$M_N$	0.05
No-load speed [ $\text{min}^{-1}$ ]	$n_0$	3,250.0
Nominal power [W]	$P_N$	14.0
Nominal current [A]	$I_N$	3.5
Nominal force [kN]	$F_N$	0.00
Duty cycle		s3

Sensor data	
Pulses	2
Output channels	1

Other data	
Gear ratio	
Gear wheel material	
Suppression components	7,5 $\mu$ H
Enclosure class	IP 40
Weight [kg]	0.520

Remarks:

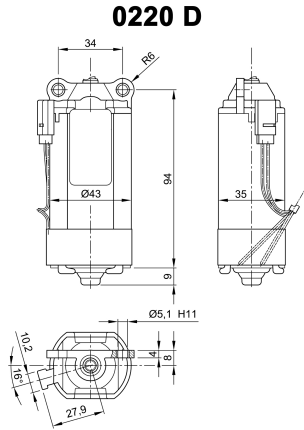

### Motor picture

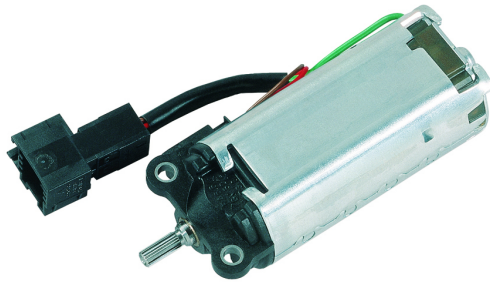

### Characteristic curves

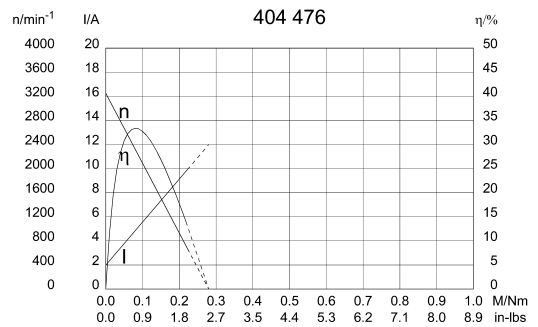

### Output shaft drawing (W), Wiring diagrams (S) and Connector layout (K)

#### W 256

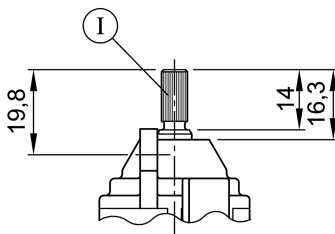

I Tapered splines 5 x 6 DIN 5481

#### S 82

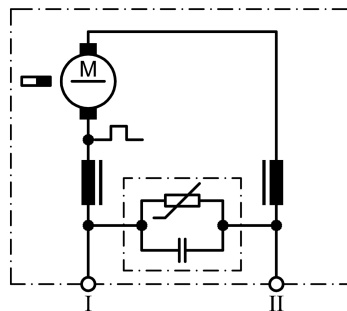

I Terminal 1, green  
 II Terminal 2, black

#### S 92

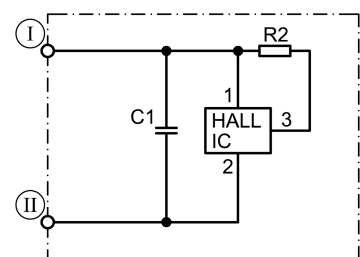

I Terminal 3, +, red  
 II Terminal 4, -, brown

Output shaft drawing (W), Wiring diagrams (S) and Connector layout (K)

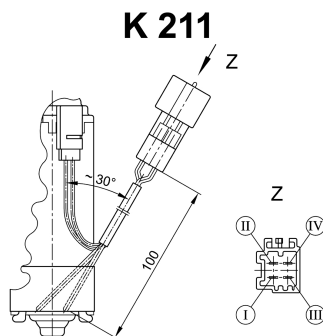

- I Terminal 1, motor, green
- II Terminal 2, motor, black
- III Terminal 3, Hall-IC + , red
- IV Terminal 4, Hall-IC - , brown

### Notes

---

---

---

---

---

---

---

---

---

---

---

---

---

---

---

---

---