

Technical Data

Rated voltage	U_N [Volt]	12
No-load speed	n_0 [min^{-1}]	180
Nominal torque	M_N [Nm]	1,50
ON time	%	10
ON	[min]	
Starting torque	M_A [Nm]	6,10
Gear ratio	i	29/1
Armature resistance, 2 bars	R [$\text{m}\Omega$]	
	R [$\text{m}\Omega$]	
Armature inductance, 2 bars	L [mH]	
	L [mH]	
Armature load inertia	J_R [kgm^2] $\times 10^{-6}$	
Gear wheel material	plastic	
Hall IC		X
Pulses/rev. drive shaft		29
Output channels		2
Remarks	L = 116mm ; 1 start worm	
Enclosure class		IP 40
Weight	[kg]	0,670

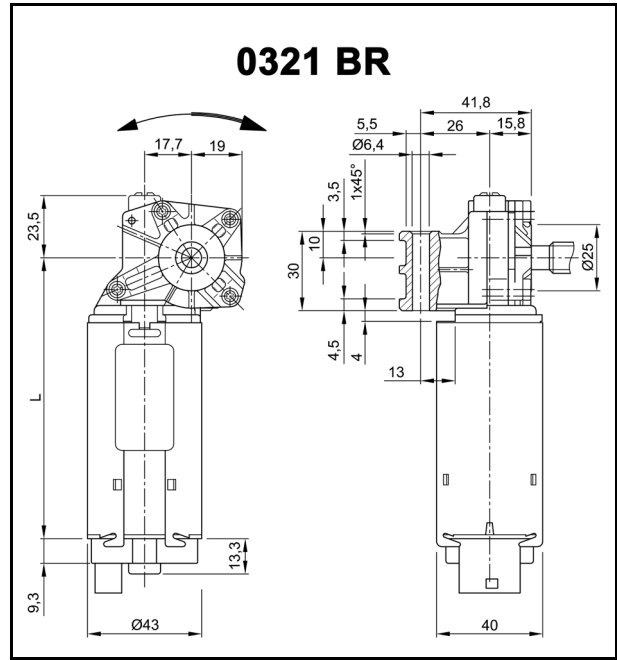

Performance and Physical Characteristics

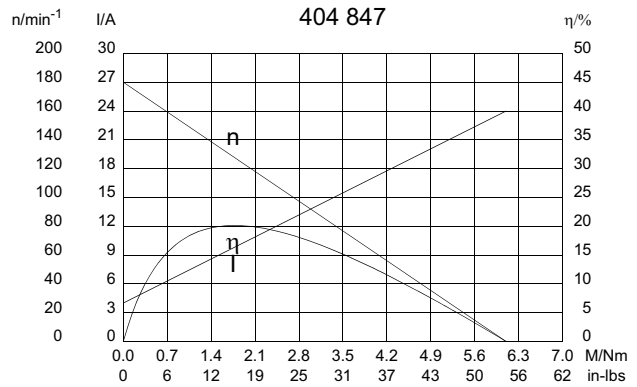

W 288

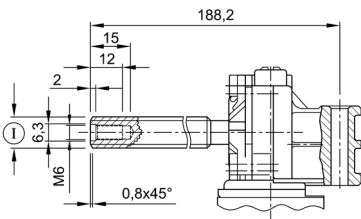

I Shaft 7/16-8 STUB ACME RH

S 93

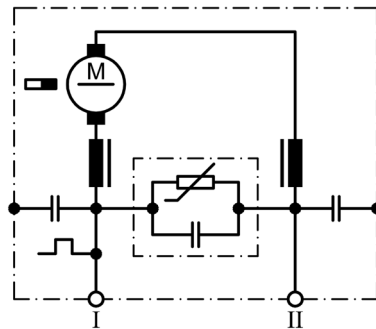

I Terminal 1
II Terminal 5

S 85

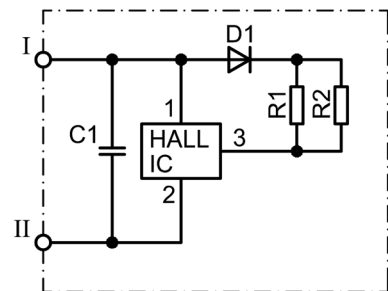

I Terminal 4, Hall-IC +
II Terminal 2, Hall-IC -

Series 0321 (GMPS)

Motor type 404 847

K 220

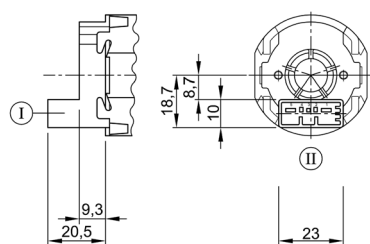

- I Terminal housing 5-pole
TYCO C-208-15621 (Z)
- II Mating connector TYCO 1379217-3
+ TYCO 1379218-2

Notes: