

# Baureihe 0277 (SW2K)

## Motortyp 403 931

### Technische Daten

Nennspannung	$U_N$	[Volt]	24
Leerlaufdrehzahl	$n_0$	[min <sup>-1</sup> ]	126
Nennmoment	$M_N$	[Nm]	2,00
Einschaltdauer	%		
EIN	[min]		
Anlaufmoment	$M_A$	[Nm]	15,50
Getriebeübersetzung	$i$		70/4
Ankerwiderstand, 2 Lamellen	R	[mΩ]	2100,00
4 Lamellen	R	[mΩ]	1700,00
Ankerinduktivität, 2 Lamellen	L	[mH]	3,60
4 Lamellen	L	[mH]	3,25
Läuferträgheitsmoment	$J_R$	[kgm <sup>2</sup> ] × 10 <sup>-6</sup>	72,00
Zahnradwerkstoff		Kunststoff	
Hall IC			
Impuls/Umdrehung Antriebswelle			
Ausgangskanäle			
Bemerkungen		Kugellager	
Schutzart			IP 40
Gewicht		[kg]	1,200

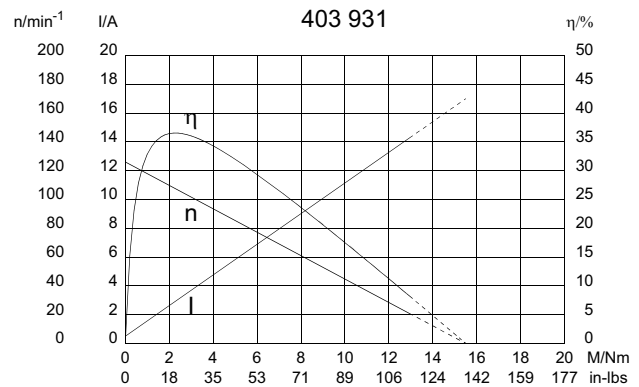
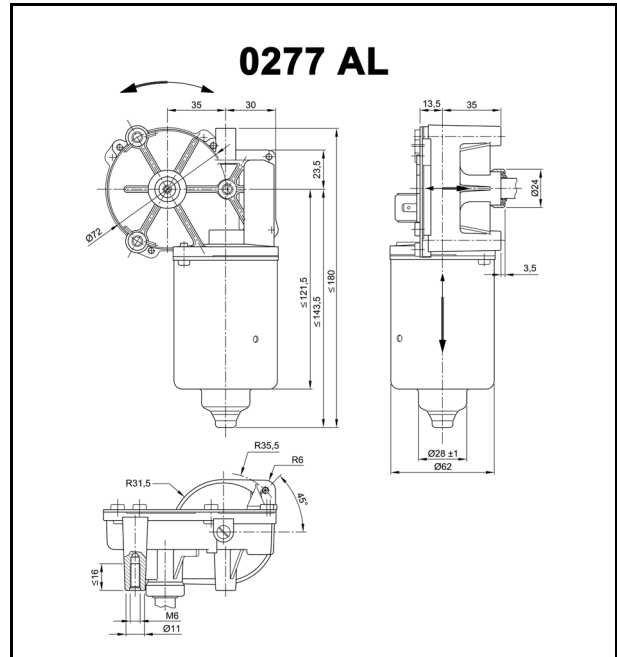

### W 191

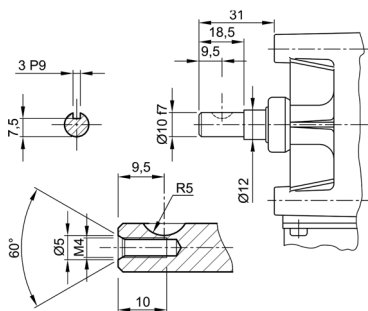

### W 197

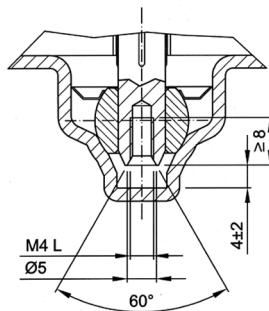

! Linksgewinde

### S 28

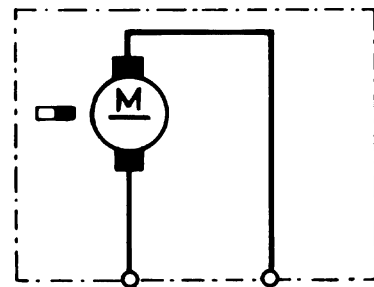

# Baureihe 0277 (SW2K)

---

## Motortyp 403 931

K 144

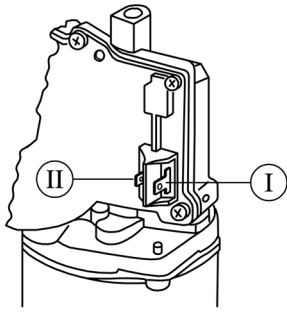

I Flachsteckerenden 6,3 x 0,8 DIN 46 244

II Flachsteckerenden 4,8 x 0,8 DIN 46 244

Notizfeld: